

WEAR-RESISTANT
FINE CONTROL

Fujikin



FINE CERAMIC BALL VALVES

CORROSION-RESISTANT

ACCURACY

PERFORMANCE
FULLY CERAMIC

Fujikin

Since its introduction in 1975, the revolutionary Phoenix Ceramic Ball Valve quickly became a popular, top-selling product worldwide. Our pioneering development of the world's first ceramic ball valve allowed engineers and maintenance personnel to finally conquer even the most aggressive services. The Phoenix Ceramic Ball Valve was so unique and ahead of its time, that one year after its introduction in the US, it won the prestigious Vaaler Award from Chemical Processing. Its outstanding development provided a more efficient and effective operation of plants in the chemical processing industries.

To further establish our commitment to our customers and stand behind the fine craftsmanship that goes into every product we manufacture, we were the first again to offer a two-year warranty against virtually anything that may cause our valves to fail. This offers our customers peace of mind when it comes to specifying the most respected, most experienced ceramic valve company in the world.

However innovative and advanced our products may be, we constantly listen to our customer needs, striving to improve on what may seem to be perfection.

This forward-thinking mindset led to the development of our second-generation ceramic ball valve – the Cosmix Ceramic Ball Valve.

The Cosmix offers all of the benefits of its predecessor and more. Improvements to the valve design allow the Cosmix to be easily maintained, safer to operate, and controls aggressive and non-aggressive media much more accurately. This cost-effective design has become the standard against which all severe-service valves are measured.

Fuji

Why Choose a Fujikin Ceramic Ball Valve?

Due to the advanced properties of the technical ceramics used, Fujikin Ceramic Ball Valves offer significant advantages over standard material ball valves. Fujikin valves are manufactured using solid 99.5% high-purity alumina ceramic, guaranteeing a valve that is superior in all respects, including resistance to:

- **Corrosion.** 99.5% alumina ceramic is virtually inert to almost all organic and inorganic chemicals. They do not interact with, nor contaminate the process media. They are physically and chemically stable against most acids and alkalis, and offer years of service with little or no corrosive degradation.
- **Abrasion.** 99.5% alumina ceramic is 43% harder than zirconia, 140% harder than porcelain, and 730% harder than stainless steel, an indication of the long-term wear-resistance properties of our valve materials.
- **Cavitation.** Even severe, continuous cavitation will not degrade or damage our ceramic valve components. Therefore, the Cosmix Ball Valve may be used in cavitating or high differential-pressure applications with little or no harmful effects.

Wide Selection of Trims. Each valve size offers a variety of four to five different control and round-ported valve trims. This assures highly accurate, tailored flow control as well as minimizing seat and pipe abrasion due to oversized trims.

2-Year Warranty

By utilizing a ceramic material that is both corrosion and abrasion-resistant, we offer an extra level of security to our customers by offering up to a 2-year warranty against corrosion, abrasion, and/or faulty workmanship.



FUJIKIN

Fujikin Ball Valve Ceramic Materials

To meet the stringent requirements mandated by the needs of modern industry, Fujikin Ball Valves are manufactured utilizing a wide variety of ceramic materials – with each possessing unique characteristics. Alumina ceramics are by far the most commonly used ceramic materials, and are commercially available in varying purities – from a porous 76% refractory material to an inert 99.9% grade. Although low-purity alumina is a relatively low cost alternative, important properties such as hardness and corrosion-resistance are drastically reduced when comparing higher alumina-content grades to other ceramics. Zirconia, silicon carbide and silicon nitride each possess a variety of unique characteristics and are all available for use in Fujikin Ceramic Ball Valves.

99.5% Alumina. 99.5% alumina is the standard ceramic material utilized in all Fujikin ceramic valves. In addition to its extreme corrosion resistance and high hardness factor, alumina is also not subject to radioactive degradation, making it an ideal material for a wide variety of aggressive applications. It remains stable at extremely high temperatures, and may even be used for services exceeding 1,000°F.

99.9% Alumina. This high-grade alumina is one of the purest forms of alumina available. It has a finer particle size, is more homogenous, and has less binding material than the 99.5% alumina. As a result, the corrosion and abrasion resistance properties are dramatically increased, making this ceramic an ideal choice for the most severe services, while still maintaining a low purchase cost.

Silicon Nitride. Silicon nitride exceeds other ceramics with a remarkably high thermal shock resistance and high strength properties at elevated temperatures. Originally developed for components in internal combustion engines, turbines, and diesel glow plugs, it is also available as an optional ceramic material in Fujikin valves. It is so stable at high temperatures that it can be used with molten metals.

Silicon Carbide. Silicon carbide is only next to diamond and boron carbide in hardness, and 95% harder than our standard alumina. It exhibits high thermal conductivity, high thermal-shock resistance, and strength durability at extreme temperatures. Silicon carbide has the highest corrosion resistance of all fine ceramic materials, and is also one of the few that is resistant to HF, making this material the ceramic of last resort.

Zirconia. Zirconia has the highest strength and toughness at room temperature of all engineered ceramics. However, zirconia is less corrosion resistant and more susceptible to impingement and rubbing wear, and is therefore used primarily for high torque and/or high pressure applications.

Performance Characteristics

Materials available in Fujikin valves with their respective characteristics

	99.5% ALUMINA (Al ₂ O ₃)	99.9% ALUMINA (Al ₂ O ₃)	SILICON CARBIDE (SiC)	SILICON NITRIDE (Si ₃ N ₄)	ZIRCONIA (ZrO ₂)
COLOR	WHITE	IVORY	BLACK	CHARCOAL	LIGHT GRAY
BULK DENSITY (g/cc)	3.8	3.97	3.2	3.2	5.5
FLEXURAL STRENGTH (MPa)	379	552	552	906	620
ELASTIC MODULUS (GPa)	372	386	400	311	200
STIFFNESS/WEIGHT (GPa/g/cc)	96	97	129	94	35
COMPRESSIVE STRENGTH (MPa)	2620	3792	–	–	1750
FRACTURE TOUGHNESS (MPa•m^{1/2}. NOTCHED BEAM TEST)	4-5	4-5	3	6	11
MAXIMUM USE TEMPERATURE (°C)	1750	1900	1650	1200	500

THERMAL SHOCK RESISTANCE FOR FUJIKIN VALVES

(IMMERSION TEST, QUENCHING IN 20°C WATER)

	99.5% ALUMINA (Al ₂ O ₃)	99.9% ALUMINA (Al ₂ O ₃)	SILICON CARBIDE (SiC)	ZIRCONIA (ZrO ₂)	SILICON NITRIDE (Si ₃ N ₄)
THERMAL SHOCK RESISTANCE (°C)	50	50	75	87	200

All Fujikin valve components are manufactured and tested to the strictest quality assurance procedures, assuring the end-user a product that is flawless in its craftsmanship.

HARDNESS FACTOR

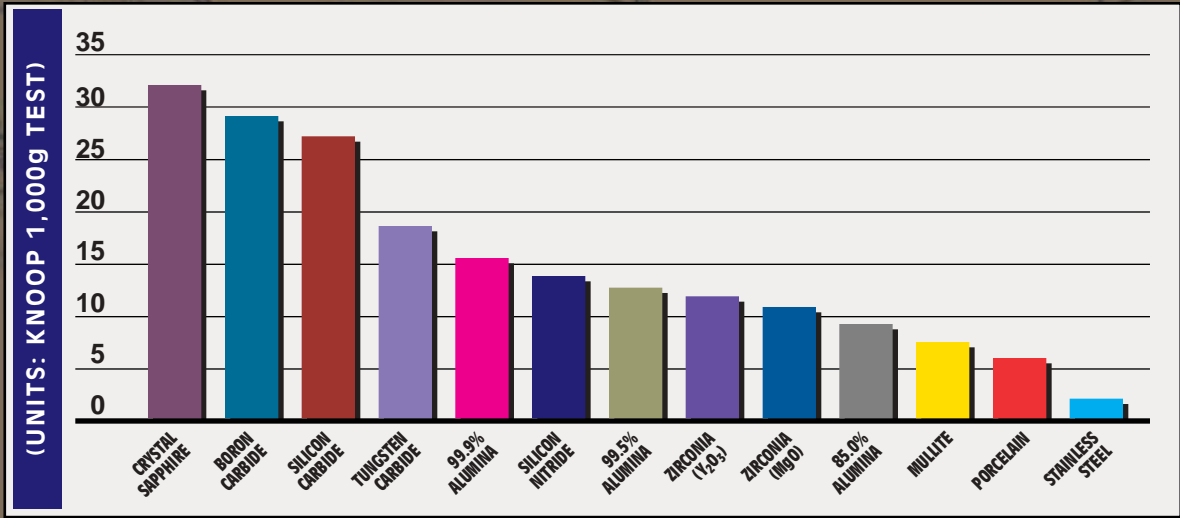

CHEMICAL DURABILITY COMPARISON CHART

(UNITS: WEIGHT LOSS; mg/cm²/day)

MEDIA	TEMP	99.5% Al ₂ O ₃	99.9% Al ₂ O ₃	ZrO ₂	SiC	Si ₃ N ₄	SS304	SS316	HC [®]	STELLITE [®] #6	STELLITE [®] #12
20% HCl	60°C	A	A	A	A	B	C	C	B	C	C
20% HCl	95°C	A	A	A	A	C	-	-	C	C	C
90% H ₂ SO ₄	60°C	A	A	A	A	A	C	C	B	B	C
90% H ₂ SO ₄	95°C	A	A	A	A	B	C	C	C	-	-
60% H ₃ PO ₄	60°C	A	A	A	A	C	C	C	A	B	A
60% H ₃ PO ₄	95°C	A	A	A	A	C	C	C	A	C	C
10% HF	60°C	B	B	C	A	A	C	C	B	C	C
46% HF	95°C	C	C	C	A	C	-	-	C	-	-
60% HNO ₃	60°C	A	A	A	A	C	A	A	C	A	A
60% HNO ₃	95°C	B	A	A	A	C	B	B	C	B	C
30% NaOH	60°C	B	A	A	A	B	A	A	A	C	A
30% NaOH	95°C	B	A	B	A	C	A	B	A	-	B

A = < 0.1 mmg/cm²/day Negligible or no corrosion, and recommended for this service
 B = 0.1 ~ 0.3 mmg/cm²/day Little or slight corrosion; Use with annual inspection
 C = > 0.3 mmg/cm²/day Significant corrosion, and not recommended for valve use
 - = Test not completed due to violent corrosion

The data in the above charts were obtained under controlled test conditions, and actual valve characteristics and performance may increase or decrease depending upon actual installation conditions.

Cosmix Ball Valve Parts List

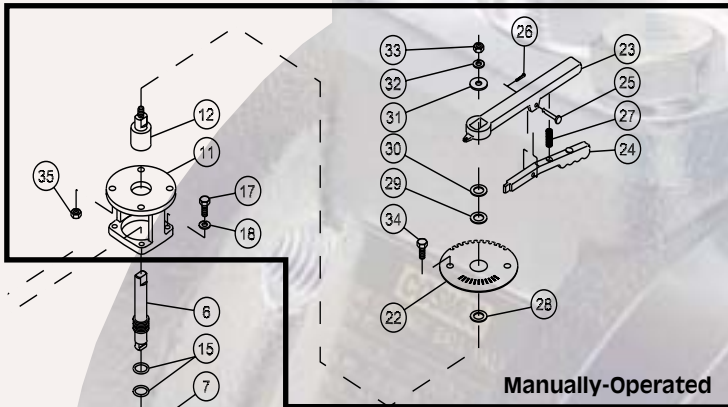
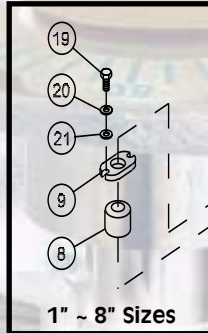
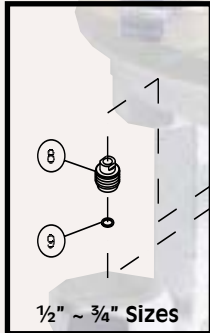
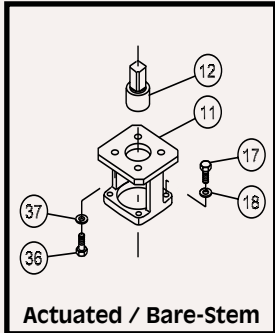

PART NO.	PART NAME	MATERIAL	QTY/REMARKS
1	BODY	CERAMIC	1 EA
2	SOCKET	CERAMIC	1 EA
3	BALL	CERAMIC	1 EA
4	HOUSING	SS304	1 EA
5	FLANGE	SS304	1 EA
6	STEM	Hastelloy-C22®	1 EA
7	PACKING BOX	C-PTFE	1 EA
8	GLAND BUSHING	SS304	1 EA (1/2"~3/4" SIZES)
8	GLAND BUSHING	C-PTFE	1 EA (1"~ 8" SIZES)
9	THRUST PACKING	PTFE	1 EA (1/2"~3/4" SIZES)
9	GLAND FLANGE	SS304	1 EA (1"~ 8" SIZES)
10	SHEET PACKING	PTFE	2 EA
11	MOUNTING PAD/YOKE	SS304	1 EA
12	COUPLING	SS304	1 EA
13	O-RING 1	FPM	1 EA
14	O-RING 2	FPM	1 EA
15	O-RING 3	FPM	2 EA
16	CAP BOLT	SS304	4 EA (1/2"~ 3" ANSI 150#) 8 EA (4"~ 8" ANSI 150#)
17	HEX BOLT	SS304	4 EA
18	LOCK WASHER	SS304	4 EA
19	HEX BOLT	SS304	2 EA
20	LOCK WASHER	SS304	2 EA
21	WASHER	SS304	2 EA
22	INDICATOR/SCALE PLATE	SS304	1 EA
23	HANDLE	CAST ALUMINUM	1 EA
24	CLUTCH LEVER	CAST ALUMINUM	1 EA
25	PIN	SS304	1 EA
26	COTTER PIN	SS304	1 EA
27	SPRING	SS304	1 EA
28	THRUST SHEET	PTFE	1 EA
29	THRUST SHEET	PTFE	1 EA
30	THRUST SHEET	PTFE	1 EA
31	WASHER	SS304	1 EA
32	LOCK WASHER	SS304	1 EA
33	HEX NUT	SS304	1 EA
34	HEX BOLT	SS304	1 EA
35	HEX NUT	SS304	1 EA
36	HEX BOLT	SS304	4 EA
37	LOCK WASHER	SS304	4 EA
38	SET SCREW	SS304	1 EA (1/2"~ 3/4" SIZES)

Exploded View

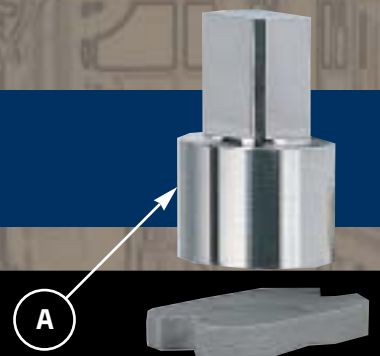
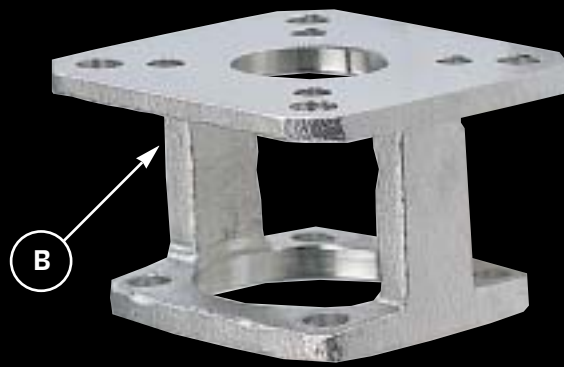

**DESIGNED
BY
DTO
ENDURE**

E

O

R

H

D



N

I

K

P

O

M



(A) Stainless Steel Coupling meets most square-drive actuator dimensions. Supplied coupling is typically the only component that may require modification for non-standard automation.

(B) Stainless Steel Mounting Pad provided with every valve meets the dimensional standards of ISO 5211 – which is the basis for a sturdy, clean, direct-fit onto most rotary actuator brands and models. The mounting pad may be removed to permit special automation packages, thus making the Cosmix valve very automation-friendly.

(C) Stainless Steel Housing allows the valve to be exposed to extremely harsh environments without external corrosive degradation. It securely encloses the ceramic components, and protects them from any possible damage. Pipe stresses are not transferred to the ceramics but are absorbed by the housing – as all flange bolts are bolted directly onto the housing itself.

(D) PTFE Gaskets cushion the ceramic against the stainless steel, and offer extra sealing protection should any of the ceramic components fail.

(E) Hastelloy-C® Stem offers excellent corrosion-resistant properties and ample hardness to drive the ball indefinitely. Standard stem may be replaced with virtually any material to maximize process compatibility and longevity.

(F) Solid Ceramic Body fully encapsulates the ball, and acts as the pressure-containing vessel when assembled with the socket. This ensures that aggressive fluids do not come in contact with any of the external stainless steel components.

(G) Solid Ceramic Ball resists corrosion and abrasion, and is offered in a wide variety of equal-percent and round ported styles. Floating-ball design requires very little actuation torque, and minimizes the possibility of fracture due to over-torquing. Having a minimal amount of “dead-torque” allows the ability to handle high differentials, as well as having abundant strength to shave-off any surface accumulation.

(H) Solid Ceramic Socket resists abrasion and is not marred by trapped solids. Symmetrical in design, it may be rotated during scheduled maintenance to extend useable life up to twelve times. Grooved external sealing surface guarantees leak-free installations with low bolt torque.



(I) Ceramic-to-Ceramic Seal. The ceramic ball and socket are perfectly matched to ensure a Class IV or better shutoff. Our incredibly deep sealing surface more closely resembles a socket than a seat. This maximizes the effective sealing surface which is neither marred nor scratched by particles that may find their way between the two surfaces.



(J) Thick, Solid Ceramics. Proof of a sound, highly-engineered valve design. By utilizing solid, heavy-wall ceramic components, the valve is able to survive in continuous service far longer than coated or lined valves. This adds to the durability of the valve and is less susceptible to damage from abuse or rough handling.

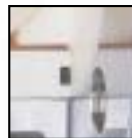

(K) Precisely Toleranced Face Seal between the body and the socket provides the primary means of keeping fluids in. A Viton® O-Ring located in the center of the face seal acts as a secondary, redundant means of providing zero external leakage.



(L) Equal Percent or Round-Port. Each line size offers up to five different trims; four equal-percent and one round-port. This variety of trims enables Fujikin to specify the perfect trim for precise control and minimized down stream seat wear.



(M) Stainless Steel Flange is held in place with flush hex socket bolts. This allows quick access to all internal components without the need for special tools, complicated alignment and assembly procedures, or time-consuming factory returns. In fact, valve repair is so simple and quick, we recommend it be done on-site.



(N) Dual, Redundant Stem Seals help reduce fugitive emissions and lower the required operating torque. The metal-to-C-PTFE contact is the primary sealing surface; the triple O-Rings ensure nothing gets by.



(O) Carbon-Filled Teflon® is stiffer, has a higher temperature limit, and does not cold-flow. O-Rings are kept energized without the need for periodic packing re-adjustment.



(P) Raised Ceramic Face ensures a leak-free installation by compressing the gasket only where needed – onto the ceramic face and not over the full area of the flange. With minimal bolt torque, a very tight, leak-free seal is achieved.



(Q) Weep Hole. An important feature if any ceramic component has fractured. Drilled through the bottom of the housing, the weep hole controls and directs any leakage down, away from equipment and personnel. It may also be threaded to connect to a pressure-sensing device, which will alert the operator of a possible fracture. Of course, the weep hole may be welded shut to prevent any leakage whatsoever.



(R) Serialization enables us to follow every valve's history – from manufacture to repair – information that allows constant product improvement and development. All ceramic components – as well as valve assemblies – are assigned a unique serial number, which provides our end users with an increased level of technical support and order history tracking.

Specifications and Dimensions

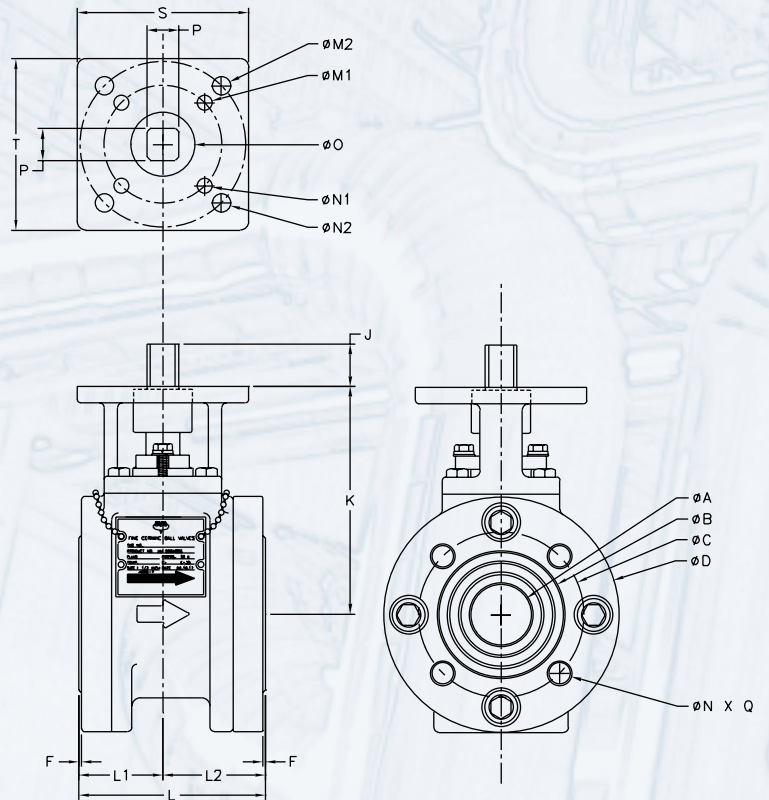

MANUALLY-OPERATED AND BARE-STEM

VALVE SIZE	ØA	ØB	ØC	ØD	F	G	H	I	J	K	S	T	L	L1	L2	ØM1	ØM2	ØN1	ØN2	ØO	P	Q(QTY)	ØN
1/2"	0.47	1.57	2.38	3.74	0.04	0.28	4.10	5.91	0.79	3.35	2.60	2.60	2.80	1.30	1.50	0.35	0.35	1.97	2.76	0.94	0.431	4	UNC 1/2"
3/4"	0.67	1.89	2.75	3.94	0.04	0.28	4.22	5.91	0.85	3.46	2.60	2.60	3.13	1.38	1.75	0.35	0.35	1.97	2.76	0.94	0.549	4	UNC 1/2"
1"	0.91	2.20	3.12	4.92	0.06	0.28	5.48	5.91	0.87	4.72	2.60	2.60	3.35	1.54	1.81	0.35	0.35	1.97	2.76	1.18	0.549	4	UNC 1/2"
1 1/2"	1.42	2.99	3.88	5.51	0.06	0.36	6.19	7.09	1.00	5.31	3.94	3.94	4.37	1.97	2.40	0.35	0.43	2.76	4.02	1.50	0.746	4	UNC 1/2"
2"	1.73	3.70	4.75	6.10	0.06	0.36	6.46	7.09	1.00	5.59	3.94	3.94	4.72	2.24	2.48	0.35	0.43	2.76	4.02	1.50	0.746	4	UNC 3/8"
2 1/2"	2.20	4.09	5.51	6.89	0.06	0.36	6.78	7.09	0.91	6.42	4.57	4.57	5.51	2.64	2.87	0.35	0.43	2.76	4.02	2.17	0.864	4	UNC 3/8"
3"	2.83	4.88	6.00	7.83	0.06	0.36	7.01	7.09	1.00	7.09	3.94	4.57	6.48	3.15	3.33	0.35	0.43	2.76	4.02	2.36	0.864	4	UNC 3/8"
4"	3.50	5.83	7.50	9.02	0.06	Please consult with Fujikin for assistance with specifying approved gear operators.			1.30	7.87	3.94	5.51	7.62	3.74	3.88	0.35	0.43	2.76	4.02	2.56	1.059	8	UNC 3/8"
6"	5.28	8.35	9.50	12.20	0.10				1.38	10.24	5.51	6.30	9.84	4.78	5.06	0.43	0.67	4.02	5.51	3.15	1.059	8	UNC 3/4"
8"	6.30	10.24	11.75	14.17	0.10				1.38	11.42	5.51	7.09	11.22	5.51	5.71	0.67	0.71	4.02	5.51	3.93	1.059	8	UNC 3/4"

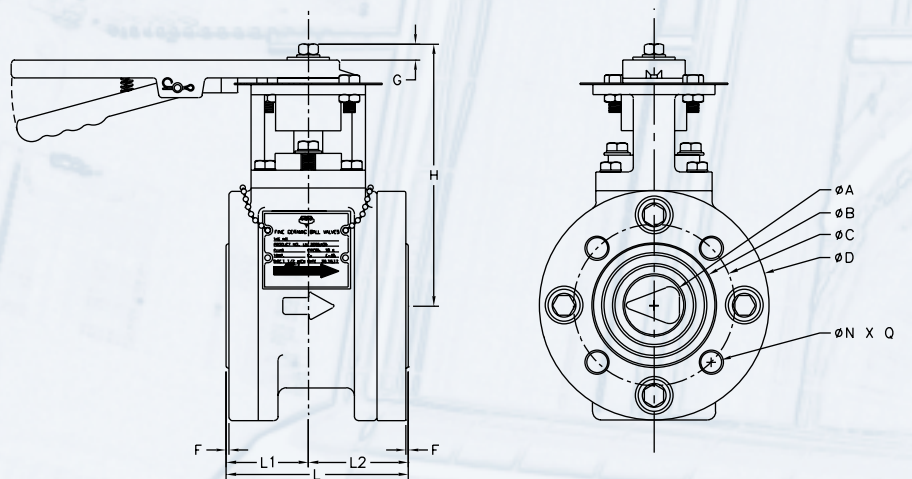

ON/OFF (ACTUATOR ONLY)

VALVE SIZE	ØA	ØB	ØC	ØD	F	G-SR	G-DA	H-SR	H-DA	J-SR	J-DA	L	L1	L2	K(QTY)	N
½"	0.47	1.57	2.38	3.74	0.04	3.38	3.13	7.29	7.29	3.81	1.81	2.80	1.30	1.50	4	UNC ½"
¾"	0.67	1.89	2.75	3.94	0.04	4.02	3.13	7.91	7.40	4.09	1.81	3.13	1.38	1.75	4	UNC ½"
1"	0.91	2.20	3.12	4.92	0.06	4.02	3.13	9.17	8.66	4.09	1.81	3.35	1.54	1.81	4	UNC ½"
1½"	1.42	2.99	3.88	5.51	0.06	5.26	3.92	10.75	10.23	4.48	4.26	4.37	1.97	2.40	4	UNC ½"
2"	1.73	3.70	4.75	6.10	0.06	5.26	3.92	11.03	10.51	4.48	4.26	4.72	2.24	2.48	4	UNC ⅝"
2½"	2.20	4.09	5.51	6.89	0.06	7.09	4.35	12.84	11.86	4.87	4.48	5.51	2.64	2.87	4	UNC ⅝"
3"	2.83	4.88	6.00	7.83	0.06	7.09	5.57	13.51	13.51	4.87	4.87	6.48	3.15	3.33	4	UNC ⅝"
4"	3.50	5.83	7.50	9.02	0.06	7.62	6.00	15.79	15.79	5.71	5.71	7.62	3.74	3.88	8	UNC ⅝"
6"	5.28	8.35	9.50	12.20	0.10	10.18	7.62	21.62	20.08	6.96	6.45	9.84	4.78	5.06	8	UNC ¾"
8"	6.30	10.24	11.75	14.17	0.10	12.54	8.35	24.29	22.80	7.59	6.96	11.22	5.51	5.71	8	UNC ¾"

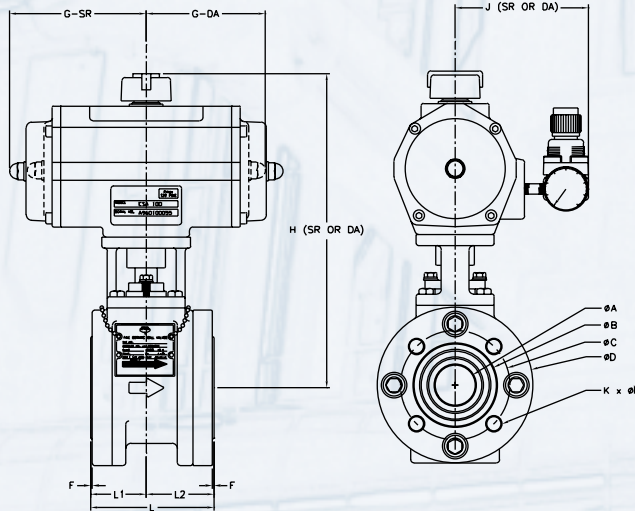

THROTTLING (ACTUATOR AND POSITIONER)

VALVE SIZE	ØA	ØB	ØC	ØD	E	F	G-SR	G-DA	H-SR	H-DA	J1 (3-15 psig)	J2 (4-20mA)	L	L1	L2	K(QTY)	N
½"	0.47	1.57	2.38	3.74	5.59	0.04	3.38	3.13	11.89	11.89	2.52	4.21	2.80	1.30	1.50	4	UNC ½"
¾"	0.67	1.89	2.75	3.94	5.59	0.04	4.02	3.13	12.51	12.00	2.52	4.21	3.13	1.38	1.75	4	UNC ½"
1"	0.91	2.20	3.12	4.92	5.59	0.06	4.02	3.13	13.77	13.26	2.52	4.21	3.35	1.54	1.81	4	UNC ½"
1½"	1.42	2.99	3.88	5.51	5.59	0.06	5.26	3.92	15.35	14.83	2.52	4.21	4.37	1.97	2.40	4	UNC ½"
2"	1.73	3.70	4.75	6.10	5.59	0.06	5.26	3.92	15.63	15.11	2.52	4.21	4.72	2.24	2.48	4	UNC ⅝"
2½"	2.20	4.09	5.51	6.89	5.59	0.06	7.09	4.35	17.44	16.46	2.52	4.21	5.51	2.64	2.87	4	UNC ⅝"
3"	2.83	4.88	6.00	7.83	5.59	0.06	7.09	5.57	18.11	18.11	2.52	4.21	6.48	3.15	3.33	4	UNC ⅝"
4"	3.50	5.83	7.50	9.02	5.59	0.06	7.62	6.00	20.39	20.39	2.52	4.21	7.62	3.74	3.88	8	UNC ⅝"
6"	5.28	8.35	9.50	12.20	5.59	0.10	10.18	7.62	26.16	24.62	2.52	4.21	9.84	4.78	5.06	8	UNC ¾"
8"	6.30	10.24	11.75	14.17	5.59	0.10	12.54	8.35	28.83	27.34	2.52	4.21	11.22	5.51	5.71	8	UNC ¾"

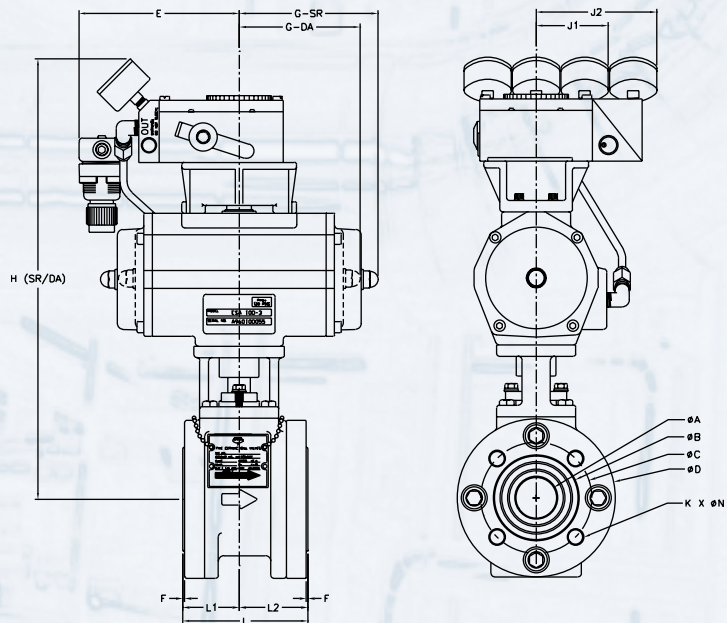

SIZE	CV VALUES				
	ROUND PORT	TRIANGULAR			
1/2"	8	4	2.5	1.5	
3/4"	14	9	5	2.5	
1"	24	17	11	7	3
1 1/2"	55	35	25	15	10
2"	90	50	34	25	15
2 1/2"	130	80	54	35	25
3"	195	120	80	58	40
4"	340	200	130	85	57
6"	750	500	350	250	
8"	1100	750	500	350	

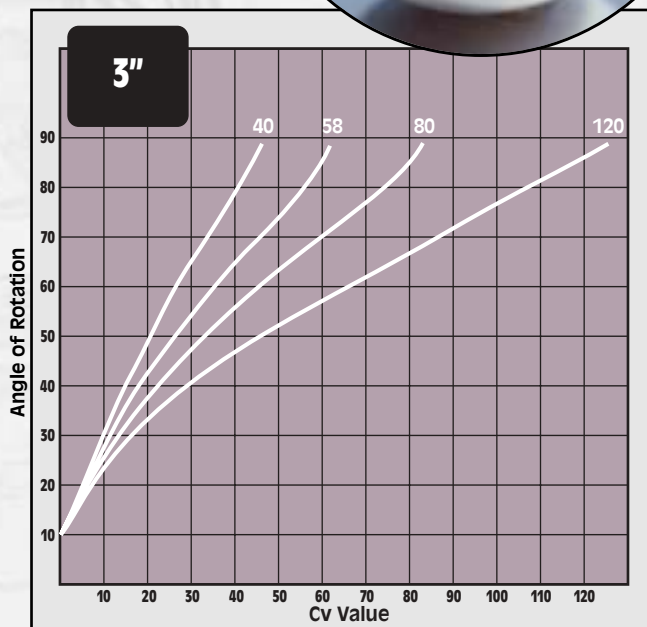
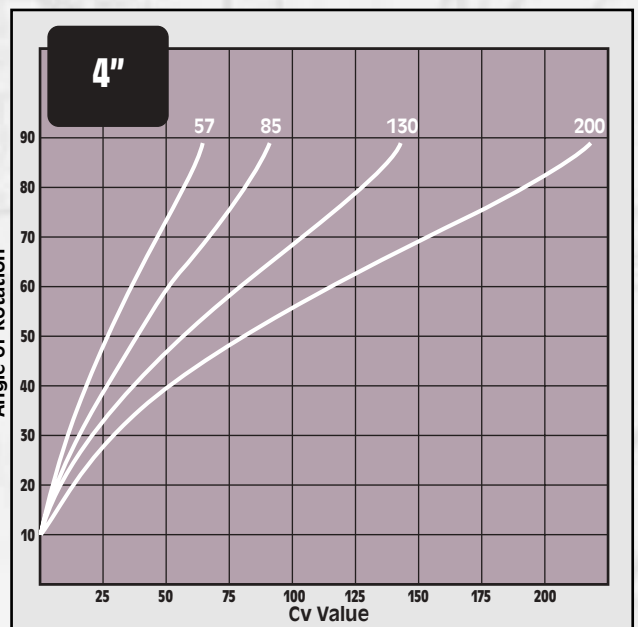
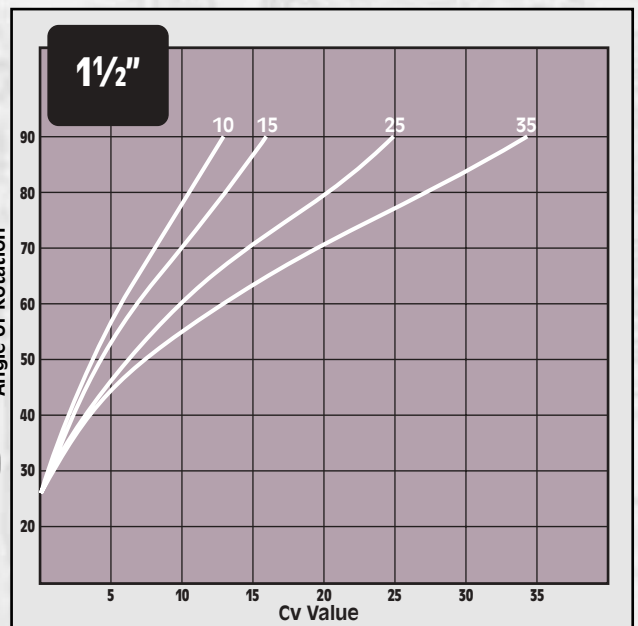
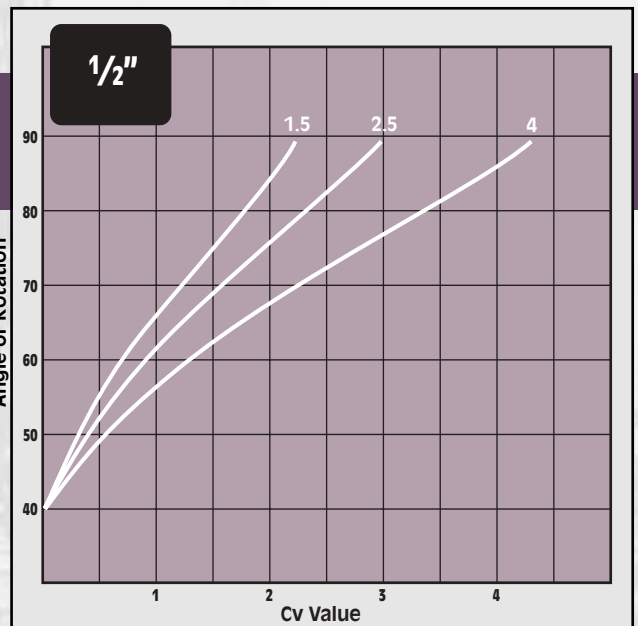

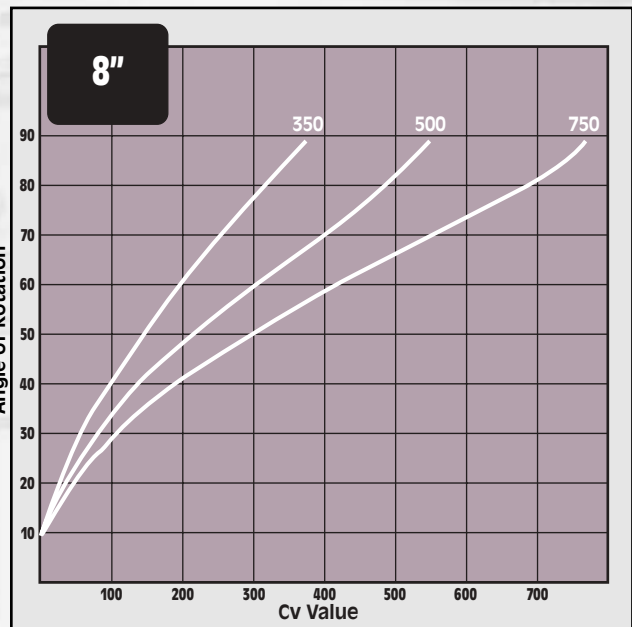
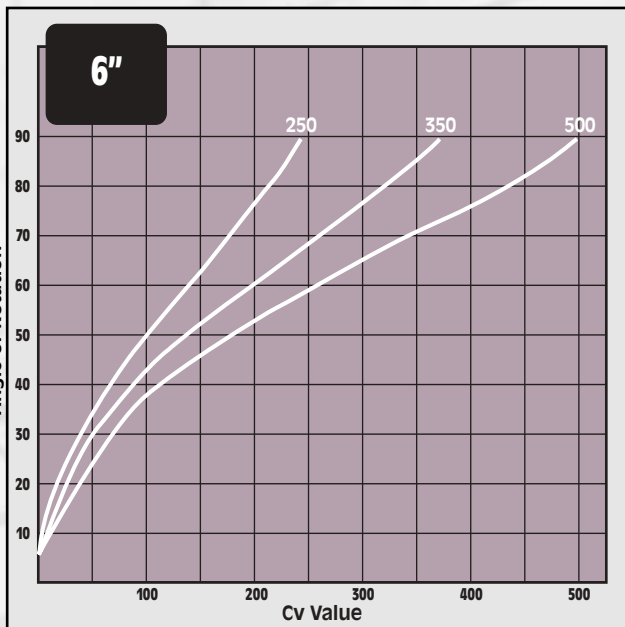
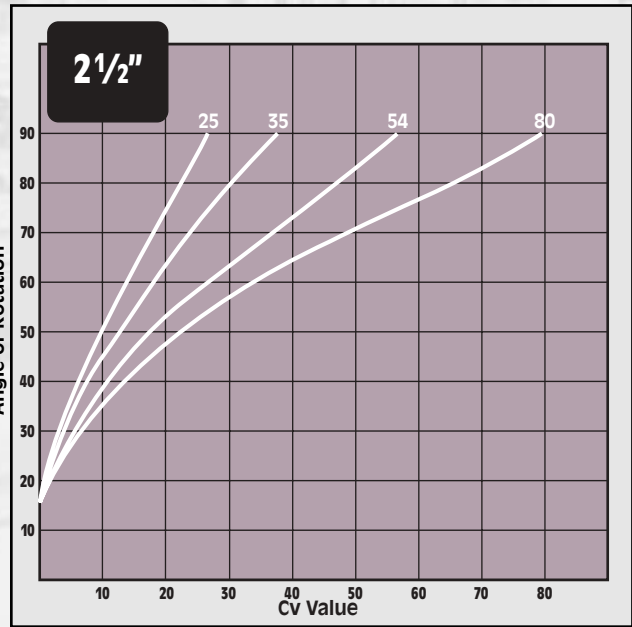
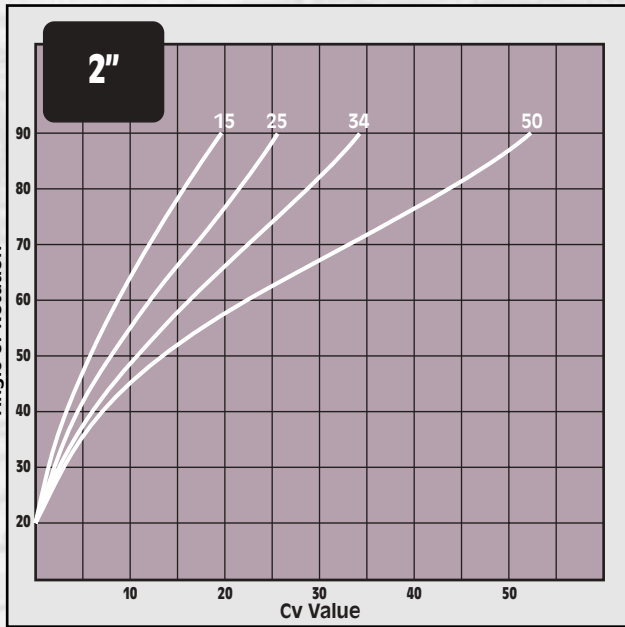
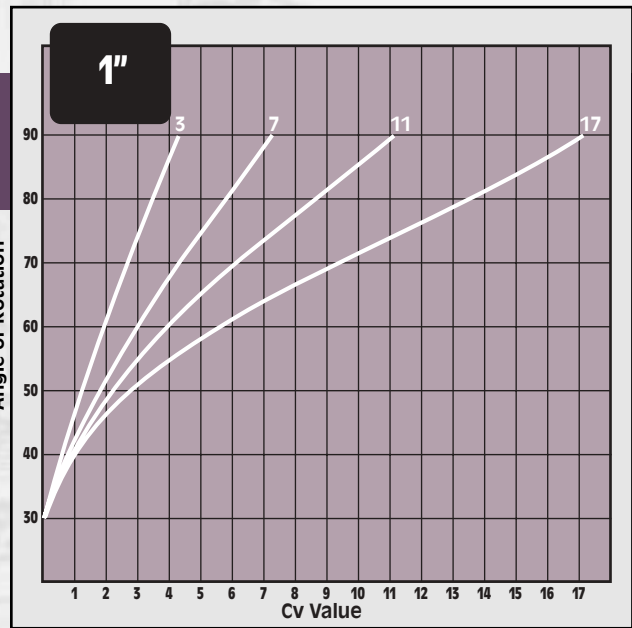
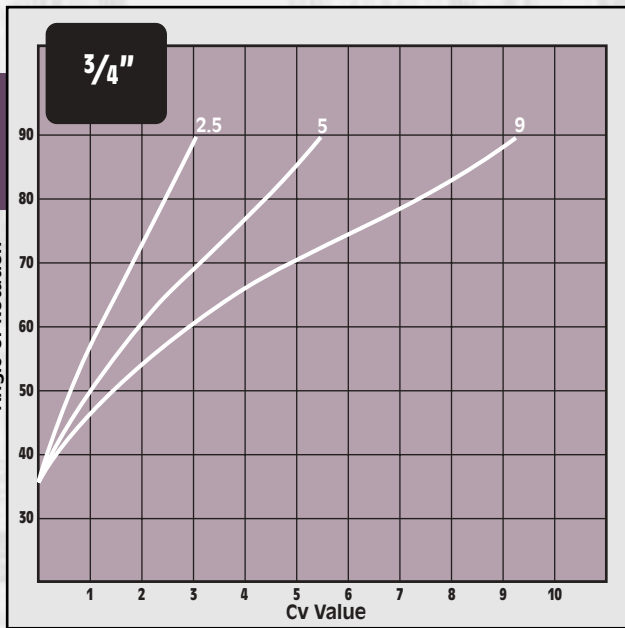

Valve Spec

Fujikin of America, Inc.

4 Alsan Way • Little Ferry • New Jersey • 07643

☎ (201) 641-1119 📠 (201) 641-1137

www.fujikin.com

End-User Information

Representative	Contact
End-User	Contact
Required Delivery	Quantity
Specification #	Tag #

Process Information

Media	<input type="checkbox"/> Gas <input type="checkbox"/> Liquid <input type="checkbox"/> Solid	% Solids	pH
Specific Gravity	SG _{min}	SG _{norm}	SG _{max}
Operating Temperature	<input type="checkbox"/> °F <input type="checkbox"/> °C	T _{min}	T _{norm} T _{max}
Maximum Possible Differential Temperature	_____ ..in _____	<input type="checkbox"/> Minutes <input type="checkbox"/> Hours	
Upstream Pressure (P ₁)	<input type="checkbox"/> psi <input type="checkbox"/> kg/cm ² <input type="checkbox"/> _____	P _{1 min}	P _{1 norm} P _{1 max}
Downstream Pressure (P ₂)	<input type="checkbox"/> psi <input type="checkbox"/> kg/cm ² <input type="checkbox"/> _____	P _{2 min}	P _{2 norm} P _{2 max}
Differential Pressure (ΔP)	<input type="checkbox"/> psi <input type="checkbox"/> kg/cm ² <input type="checkbox"/> _____	ΔP _{min}	ΔP _{norm} ΔP _{max}
Maximum Shutoff Pressure (P _{max})	Viscosity (CP)		
Flow (Q)	<input type="checkbox"/> GPM <input type="checkbox"/> m ³ /h <input type="checkbox"/> _____	Q _{min}	Q _{norm} Q _{max}
Estimated Cycles Per Hour			
Brand of Valve Currently Using		Average Service Life	

Valve Automation

<input type="checkbox"/> On-Off Operation	<input type="checkbox"/> Throttling Operation	<input type="checkbox"/> Manually Operated
<input type="checkbox"/> Fail Closed	<input type="checkbox"/> Fail Open	<input type="checkbox"/> Double Acting
Available Supply Air (psi)	<input type="checkbox"/> 4-20 mA Control Signal	<input type="checkbox"/> 3-15psi Control Signal

Piping & Installation

Line Size (inch)	<input type="checkbox"/> ANSI 150 # RF Flanged	<input type="checkbox"/> ANSI 300 # RF Flanged
Valve will be installed	<input type="checkbox"/> Horizontally	<input type="checkbox"/> Vertically
Is the Line Cleaned Periodically?	Flushing Media	Temp of Flushing Media
How Often are Scheduled Maintenance Shut-Downs?		

List additional options you require on this valve with brand and model numbers as well as important and pertinent information that we should be aware of when recommending or sizing this process.

For Fujikin Use

Recommended Valve Size	C _{v max}	C _{v norm}	C _{v min}
Ceramic Material	Stem Material		
Actuator	Positioner		
Approved Warranty Period	Delivery		
Approved By	Date		

Ceramic Valve Specification Sheet – Feb 00

Applications Ideal for Fujikin Ceramic Valves

Listed below is a small sampling of the applications and industries in which Fujikin Cosmix ceramic ball valves have proven their superior properties and longevity in hostile environments. Cosmix valves endure in the most corrosive and abrasive services far more reliably than soft-seated, metal-seated, exotic alloy, rubber-lined, and even competitive ceramic valves. Taking into consideration the frequent maintenance and replacement costs required of competitive severe-service valves, the Cosmix clearly improves on overall service life, accuracy and control, and makes excellent financial sense as well.



Acetic Acid	Copper Chloride	Milk of Lime	Sodium Fluoride
Alumina Hydrate	Copper Cyanide	Molasses	Sodium Hydroxide
Alumina Powder	Copper Sulfate	Mother Liquor	Sodium Hypochlorite
Alumina Chloride	Corn Syrup	Napthalene	Sodium Nitrate
Ammonia	Cotton Seed Oil	Natural Gas	Sodium Sulfate
Ammonium Carbonate	Cuprous Chloride	Nitric Acid	Soot Slurry
Ammonium Chloride	Diatomaceous Earth	Oleum	Steam
Ammonium Fluoride	Ethanol	Oxalic Acid	Sulfur Dioxide
Ammonium Silicate	Ethyl Amine	Paperad Slurry	Sulfuric Acid
Anatase Slurry	Ethyl Ether	Para-nitrophenol	Talcum Water
Aniline	Ferric Chloride	Perlite	Tarnic Acid
Ansilex	Ferrous Sulfate	Petroleum	Tartaric Acid
Antioch	Filler Clay	Phenol	Titanium Dioxide
Aqua Regia	Flue Gas	Phosphoric Acid	Titanium Tetrachloride
Ascorbic Acid (Vitamin C)	Flyash (Wet and Dry)	Potash Slurry	Tobacco Slurry
Ash Slurry	Formic Acid	Potassium Bromate	Toluene
Bauxite Slurry	Green Liquor	Potassium Carbonate	Trichloroethane
Bentonite Clay / Slurry	Gypsum	Potassium Chlorate	Turpentine
Benzyl Chloride	Hydrochloric Acid	Potassium Chloride	Waste Acids
Black Liquor	Hydrofluoric Acid	Potassium Dichromate	White Liquor
Boric Acid	Hydrofluosilic Acid	Potassium Perchlorate	White Water
Brine	Hydrogen Peroxide	Potassium Permanganate	Wool Fines
Calcined Clay	Hydroxyacetic Acid	Potassium Sulfate	Xylene
Calcium Carbonate	Isopropyl Acetate	Precipitated Calcium Carbonate (PCC)	Zinc Sulfate
Calcium Chlorate	Kaolin Slurry	Pulp Slurry	
Calcium Chloride	Kerosene	Radioactive Slurry	Main Industries Served
Calcium Hypochlorite	Lime / Limestone Slurry	Recycled Paper	Chemical
Calcium Sulfate	Liquid Scrubs	Rejects Slurry	Metals & Mining
Carbon Slurry	Lithium Bromide	Rutile Slurry	Petrochemical
Caustic / Caustic Slurry	Magnesium Hydroxide	Saltcake Slurry	Power & Cogeneration
Ceramic and Water Mixture	Magnesium Oxide Slurry	Sand / Tailings Slurry	Pulp & Paper
Chlorine (Wet)	Magnesium Sulfate	Sewage	Refining
Chlorosilane Vapor	Manganese Slurry / Ore	Sludge Slurry	Water & Wastewater
Chromic Acid	Mercuric Chloride	Sodium Benzoate	
Citric Acid	Methanol	Sodium Carbonate	
Clarifier UF Blowdown & Receive	Methyl Acetone	Sodium Chlorate	
Clarifier Waste from Pumps	Methyl Chloride	Sodium Chloride	
Clay Slurry	Methyl Ethyl Ketone	Sodium Cyanide	
	Methylene Chloride		

For an immediate quotation on a Cosmix ceramic ball valve, copy, fill-out, and fax the Valve Spec on the preceding page direct to Fujikin or to your nearest representative. Complete and true process information will ensure an accurate price and delivery quotation, as well as enabling us to recommend the best possible trim and material selections to maximize control, valve endurance, and longest possible warranty duration.

Product Identification Number

Please use this part number when making inquiries.

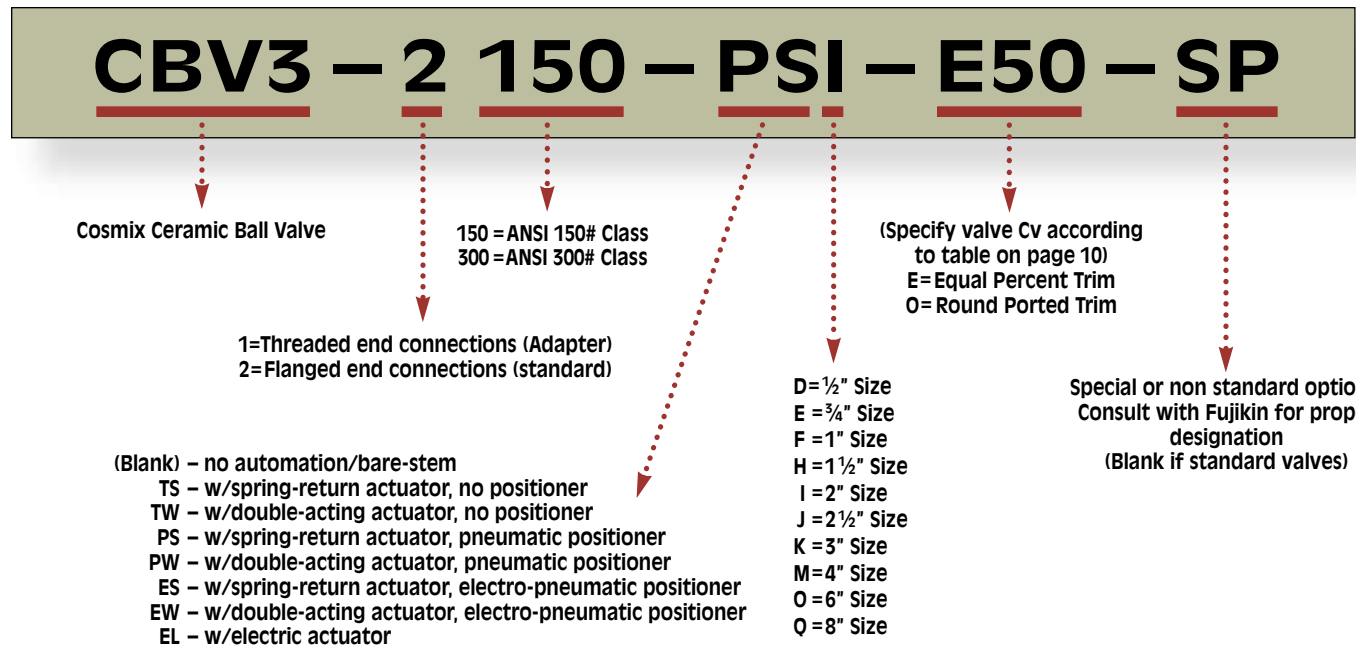

Replacement Parts

All original factory replacement parts are manufactured to the strictest of quality procedures. Extremely high tolerances are kept, and therefore 100% of parts are interchangeable, eliminating the need for matched components. Fujikin maintains an extensive inventory of all replacement parts for the Cosmix Valves. Spares can usually be shipped the same day, thus minimizing unscheduled downtime and eliminating the need for customer stocking of parts.

Fujikin 2-Year Warranty

In order to assure every Fujikin valve provides the longest possible service, our technical staff will review each process and recommend the proper valve size and trim. Additionally, each service is cross-referenced with our extensive chemical compatibility database and 25 years of installation expertise. As a result, Fujikin is able to warranty the Cosmix Valves against corrosion, abrasion, and/or faulty workmanship for up to 2-years in service. Should the valve not perform as intended, we will immediately provide free replacement parts, a new replacement valve, or repair the valve in our facility at no cost to the end-user.



The Fujikin warranty is our assurance to you, that each and every Fujikin valve is manufactured to the highest quality standards, and will provide years of maintenance-free service in the most aggressive conditions.

Operating Parameters

SIZE RANGE

½" to 8"

MAXIMUM OPERATING TEMPERATURES

Standard Configuration 200°C (392°F)

High-Temperature Configuration 600°C (1112°F)

MAXIMUM INSTANTANEOUS TEMPERATURE SHOCK

	Unprotected	With Heat-Tracing Device
Alumina	50°C (122°F)	100°C (244°F)
Zirconia	87°C (188°F)	174°C (376°F)
Silicon Carbide	75°C (167°F)	150°C (334°F)
Silicon Nitride	200°C (392°F)	400°C (784°F)

Higher instantaneous temperature differentials may be accomplished with the use of heat-tracing devices. Consult with Fujikin for proper implementation of heat-tracing devices and specific details.

OPERATING PRESSURE

Line Pressure 300 psig

Differential Pressure ½" to 2½" 150 psig
3" to 4" 100 psig
6" to 8" 70 psig

Higher line pressures and differential pressures (up to 3x the above numbers) may be achieved. Consult with Fujikin for specific details.

MAXIMUM ALLOWABLE LEAKAGE

Between 0.00001 and 0.00001 of valve Cv, Class IV or better

VALVE WEIGHTS

Size	Net Weight		Gross Weight	
	kg	lb	kg	lb
½"	2	4.5	4	9
¾"	3	7	5	11
1"	5	11	7	16
1½"	8	18	13	29
2"	10	22	16	35
2½"	15.5	34	22	48
3"	22	49	30	66
4"	33	73	40	88
6"	75	165	86	185

Teflon® is a registered trademark of DuPont Company.
Viton® is a registered trademark of Dupont Dow Elastomers.
Hastelloy-C® is a registered trademark of Haynes International, Inc.

Fujikin

REPRESENTED BY:

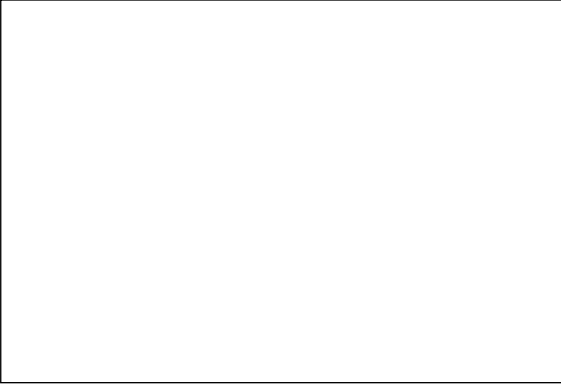

Fujikin

Fujikin of America, Inc.

4 Alsan Way

Little Ferry, New Jersey 07643-2228

201-641-1119

Fax: 201-641-1137

Visit us at www.fujikin.com

© 2000 Fujikin of America, Inc.

The contents of this brochure are subject to change without notice for further improvement.

