

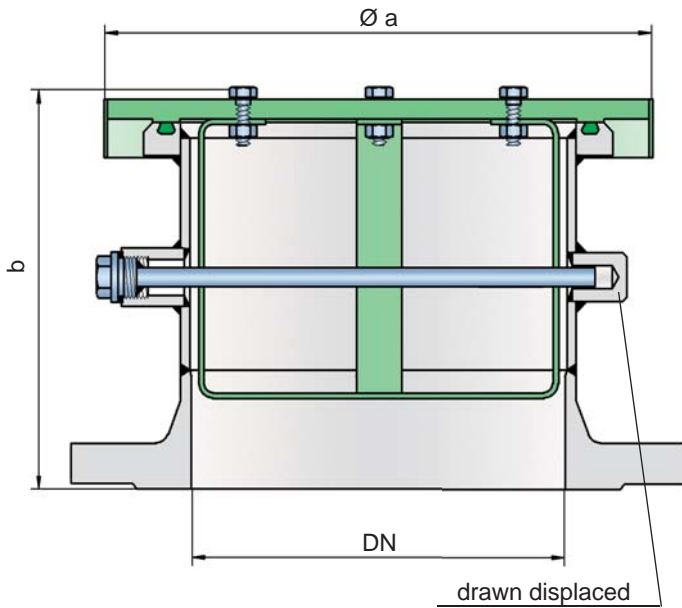

Emergency pressure relief valve

PROTEGO® ER/V



Pressure settings:

DN 200 to DN 350: +5 mbar up to +40 mbar
+2 inch W.C. up to +16 inch W.C.

DN 400 to DN 700: +5 mbar up to +25 mbar
+2 inch W.C. up to +10 inch W.C.

For higher pressure settings, see types ER/VH and ER/V-F.

Function and Description

The ER/V type PROTEGO® valve is a highly developed emergency pressure relief valve with high flow capacity. It is primarily used as a safety device for emergency pressure relief for storage tanks, containers, silos, and process engineering equipment; it offers reliable protection against overpressure and prevents impermissible product vapor loss close to the set pressure. It is designed to relief particularly large amounts to prevent the vessel from rupturing in an emergency case.

The device will start to open as soon as the set pressure is reached and only requires 10% overpressure to full lift. Continuous investments into research and development have al-

lowed PROTEGO® to develop a low pressure valve which has the same opening characteristic as a high pressure safety relief valve. This "full lift type" technology allows the valve to be set just 10% below the maximum allowable working pressure of the tank and still safely vent the required mass flow.

Due to the highly developed manufacturing technology, the tank pressure is maintained up to the set pressure, with a tightness that is far superior to the conventional standard. This feature is achieved by valve seats made of stainless steel with an inserted O-ring seal, a precisely lapped valve pallet, as well as a reinforced housing design. After the excess pressure is relieved, the valve reseats and provides a tight seal again.

Special Features and Advantages

- "full lift type" technology valve utilizes only 10% overpressure to reach full lift
- excellent tightness and hence least possible product losses and reduced environmental pollution
- the set pressure is close to the opening pressure which results in best possible pressure management of the system
- high flow capacity
- the valve pallet is guided within the housing to protect against harsh weather conditions
- can be used in areas subject to explosion hazards
- reinforced design
- safely secured housing cover
- best technology for API-tanks

Design Types and Specifications

The valve pallet is weight-loaded. Higher pressures are achieved with levers (see ER/VH) or with spring-loading (see ER/V-F).

Pressure valve in basic design

ER/V

Additional special devices available upon request

Table 1: Dimensions

Dimensions in mm / inches

To select the nominal size (DN), use the flow capacity chart on the following page

DN	200 / 8"	250 / 10"	300 / 12"	350 / 14"	400 / 16"	450 / 18"	500 / 20"	600 / 24"	700 / 28"
a	305 / 12.01	375 / 14.76	425 / 16.73	445 / 17.52	495 / 19.49	545 / 21.46	615 / 24.21	715 / 28.15	795 / 31.30
b	depending on pressure setting								

Table 2: Material selection

Design	A	B	C	D	
Housing	Steel	Steel	Stainless Steel	Stainless Steel	* depending on pressure setting
Valve seat	Stainless Steel	Stainless Steel	Stainless Steel	Stainless Steel	
Valve pallet	Aluminium*	Steel-Stainless Steel*	Aluminium*	Stainless Steel*	Special Materials upon request
Sealing	FPM	FPM	FPM	FPM	

Table 3: Flange connection type

EN 1092-1, Form B1 or DIN 2501, Form C, PN 10
ANSI 150 lbs RFSF

EN or DIN
ANSI

other types upon request

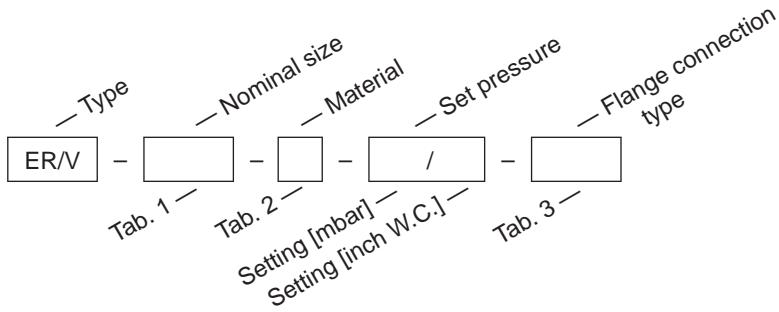

Order example



Materials and chemical resistance: See Vol. 1 "Technical Fundamentals"

Flow Capacity Chart

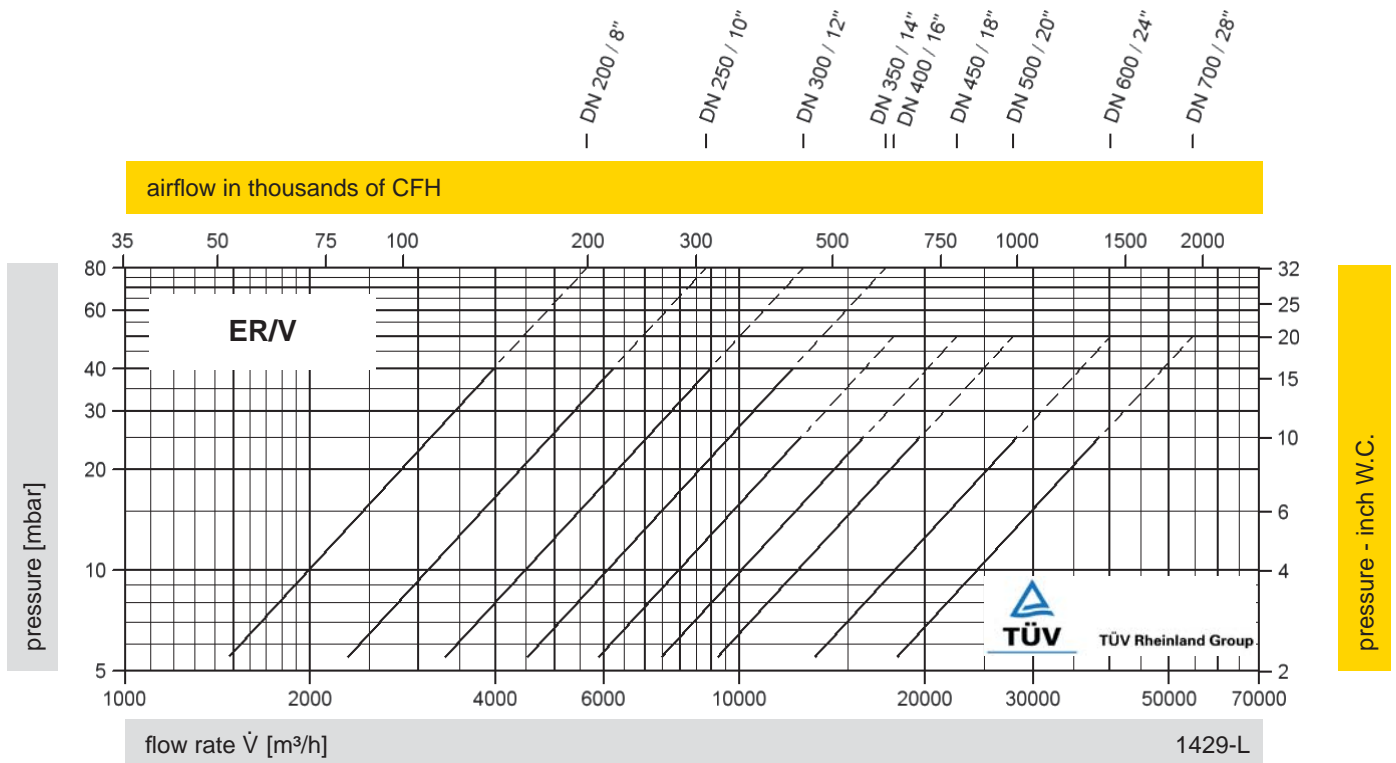

The flow capacity chart has been determined with a calibrated and TÜV certified flow capacity test rig. Volume flow \dot{V} in [m³/h] and CFH refer to the standard reference conditions of air ISO 6358 (20°C, 1bar). Conversion to other densities and temperatures refer to Vol. 1: "Technical Fundamentals".

